



PHILANTHROPIC FOUNDATION

coriander   
DESIGNS

# USER-FOCUSED PRODUCTS

PROJECT: Philanthropic Foundation Headquarters

LOCATION: Seattle, Washington

DESIGN: Coriander Designs

OVERVIEW: Innovative, ecological solutions were the central focus for the headquarters of a newly established philanthropic foundation. Open layouts required modesty and storage options, all workstations needed to include height-adjustable functionality, and materials had to be Red List free.

“Red List” materials are considered harmful or toxic to human and ecosystem health as defined by the International Living Future Institute (ILFI). Avoiding them is a commitment to prioritizing the health of the planet and also provides a safer environment for users.

Calling on our experience and extensive custom capabilities, we created a suite of furniture solutions. The pieces included adjustable height workstations with storage for private offices, administrative stations, built-in cabinets, shelving, and credenzas with height-adjustable work-surfaces, and cubbies with concealed cord management - all with the user experience and health at the forefront of each design.

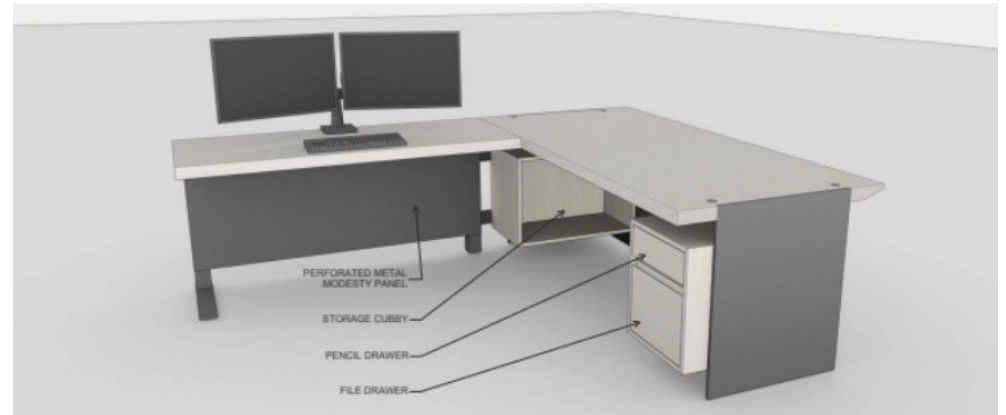
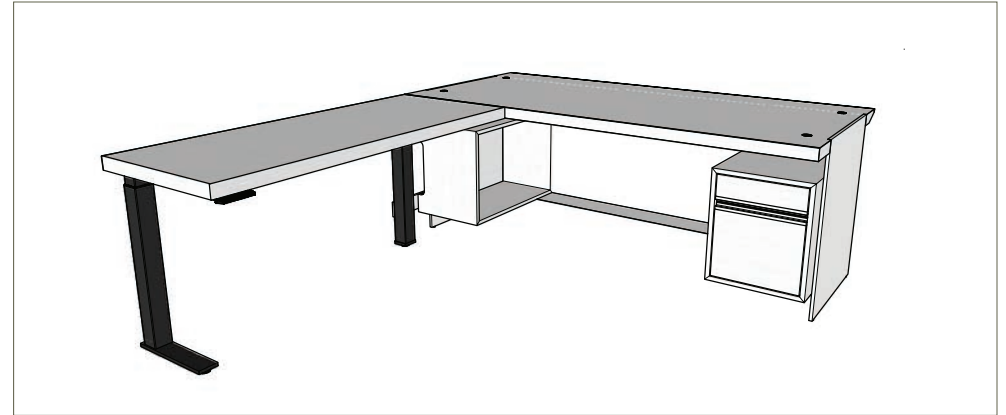

The design process from drawing to render to install.

# Executive Office Workstations

## USER-FOCUSED PRODUCTS



Built in floating shelves over a custom credenza with adjustable height surface provides plenty of workspace and storage.

Per the client's requirements that all materials be Living Building Challenge (LBC) Red List free, we used FSC® Certified Walnut veneers and were thoughtful in all our material choices from the solid Walnut end grains on all desk-tops to the metal disc bases. Materials on the LBC Red List are those used in the building industry that are harmful to human and ecosystem health to the point of causing possible risk to life and living systems. As an FSC-certified shop, we were comfortable and pleased to work within these requirements.



# Executive Office Workstations

## USER-FOCUSED PRODUCTS

Working with an understanding of the client's needs, we designed and engineered three options for the Executive Office Workstations.

Option 1 offers an open metal leg, detached from the modesty panel and a detached and wheeled pedestal.

Option 2 conceals the desk legs in veneer sleeves attached to the modesty panel, and Option 3 attaches the pedestal to the desk surround so the entire piece functions as one cohesive unit.

The final design (shown below and on the next page) changed based on further exploration of the client's needs; however, this initial process was key to pushing all parties involved toward the best solution.

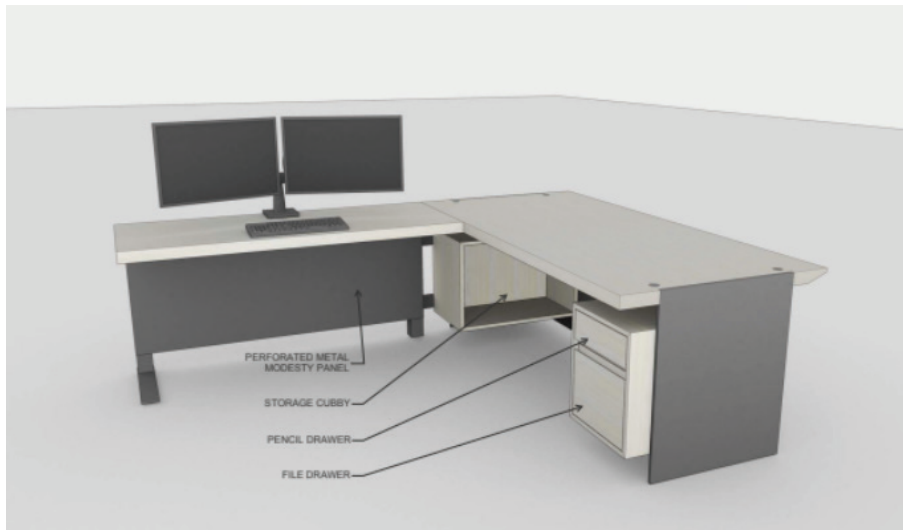

OPTION  
1

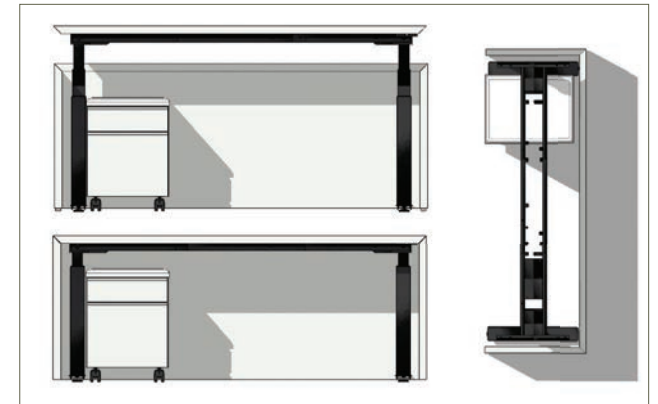

OPTION  
2

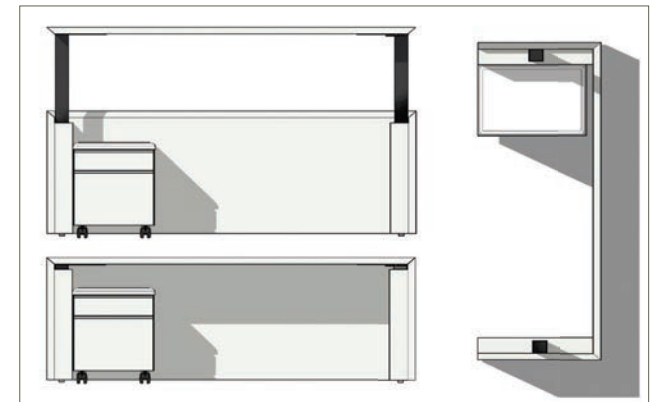

OPTION  
3

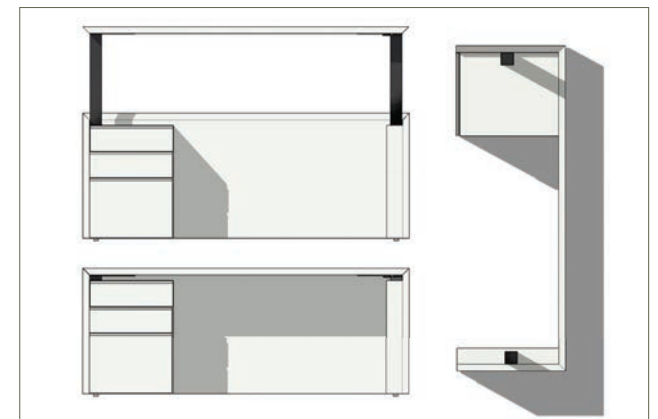

# Executive Office Workstations

## USER-FOCUSED PRODUCTS



The final design of the executive office workstations expanded the piece to an L-shaped, multi-surface adjustable height desk with a perforated metal modesty panel, floating storage cubby, and pencil and file drawer pedestal supported by 1/2" blackened steel plate legs and height adjustable square column bases in night bronze finish.

# Details

## USER-FOCUSED PRODUCTS

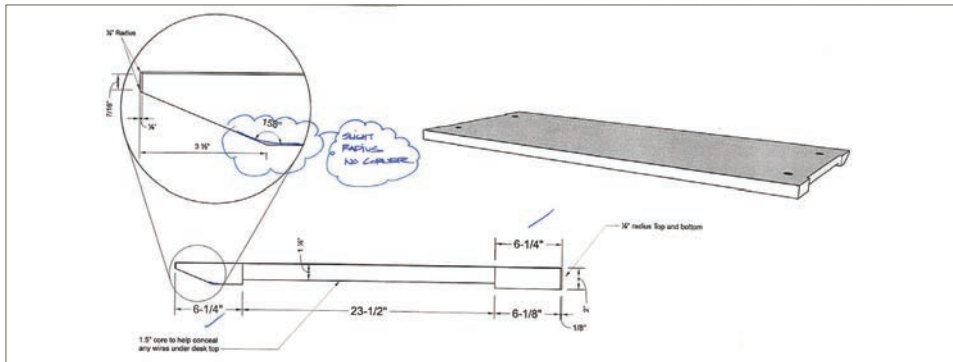
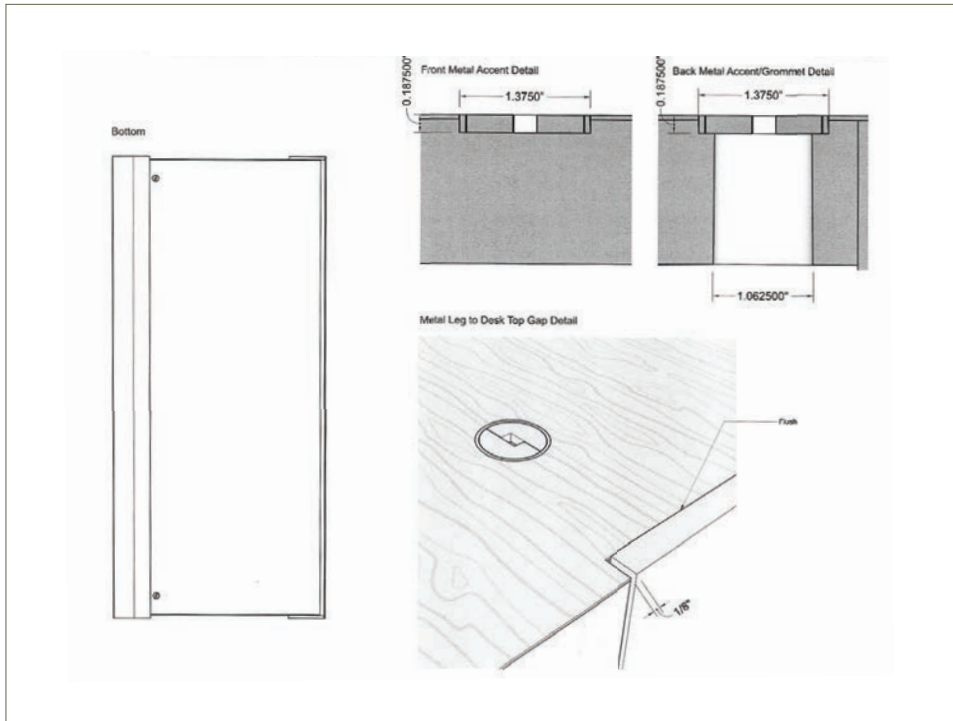

The end panel of the desk features an inset 1/2 inch blackened steel plate leg that is hugged by the desk surface when it lowers to sitting height. The front edge of the desk has a 6" deep custom reverse bevel edge that offers a lighter look. Custom black metal, magnetic grommets provide interest in addition to use with their complementary placement.

# Details

## USER-FOCUSED PRODUCTS

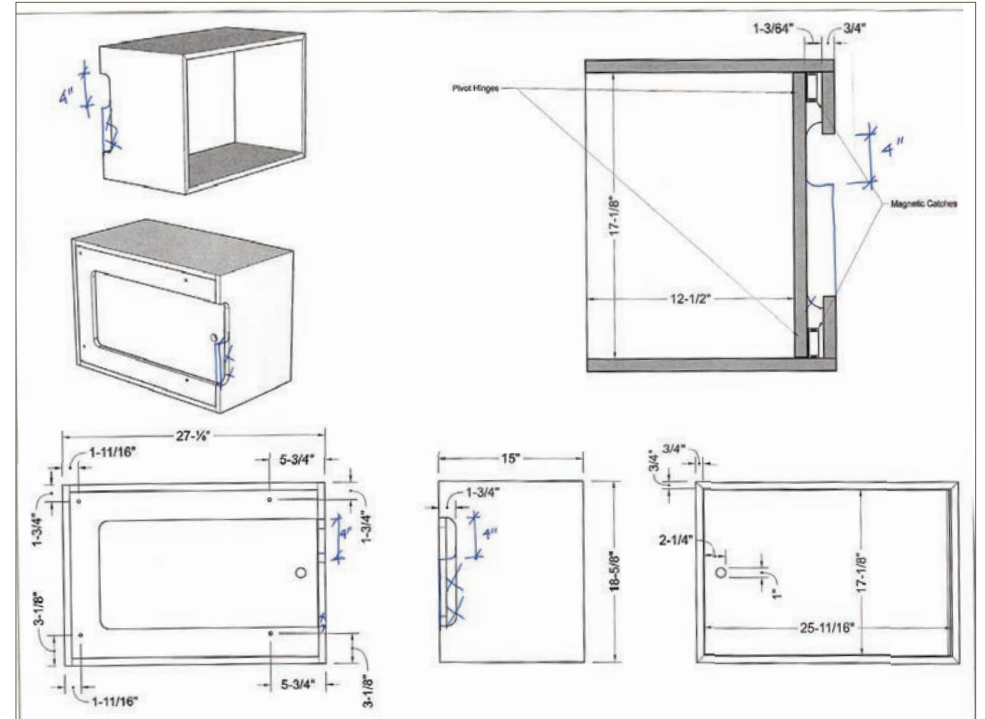
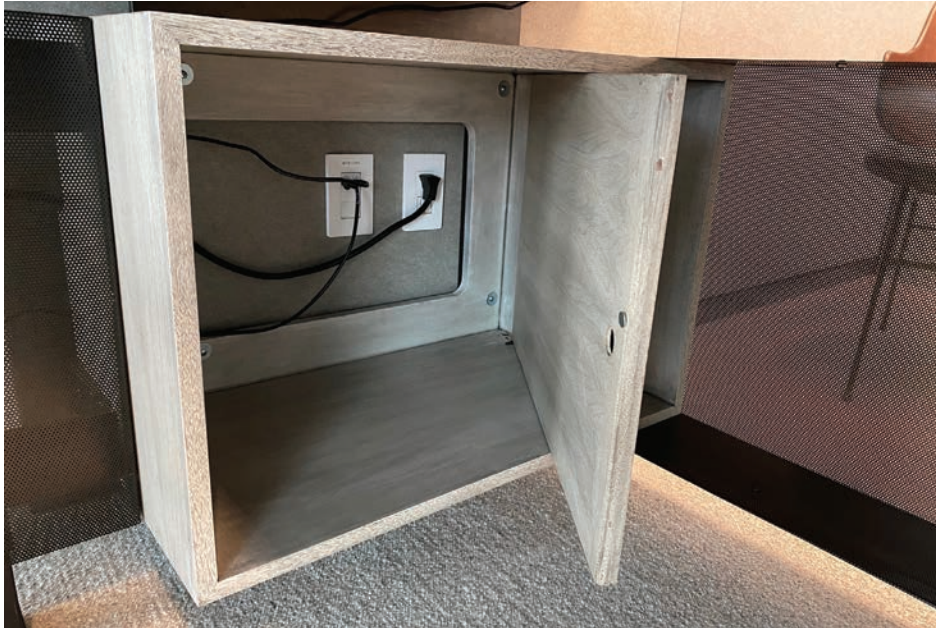

Open cubbies underneath the desktop conceal cords from the adjustable height functionality with false backs.

Within the hidden compartments are data and power units that can be accessed via a hinged, pivoting door.

Perforated metal modesty panels offer additional privacy without sacrificing light.

# Details

## USER-FOCUSED PRODUCTS

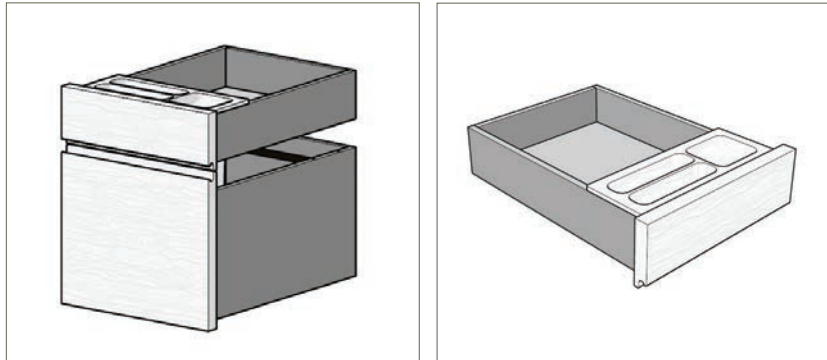
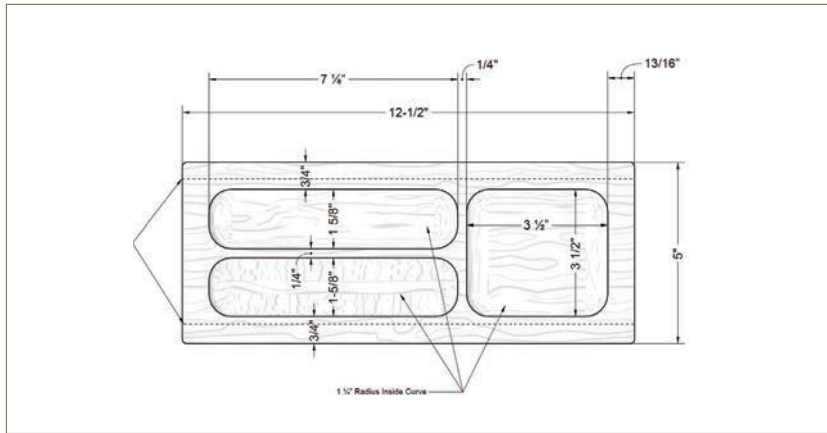

Custom pencil trays fit and slide in the top drawers of floating file cabinets concealed beneath desk surfaces.

Drawer and box insides are finished in a dark gray matte melamine, the displayed solid Walnut and FSC Walnut veneers are finished in a custom bleached ceruse, and the solid Walnut pencil trays are finished in a custom dark, complementary stain.

All drawer pulls are integrated into the fronts with easy to use finger pulls which contributes to the overall clean look of the desk system.





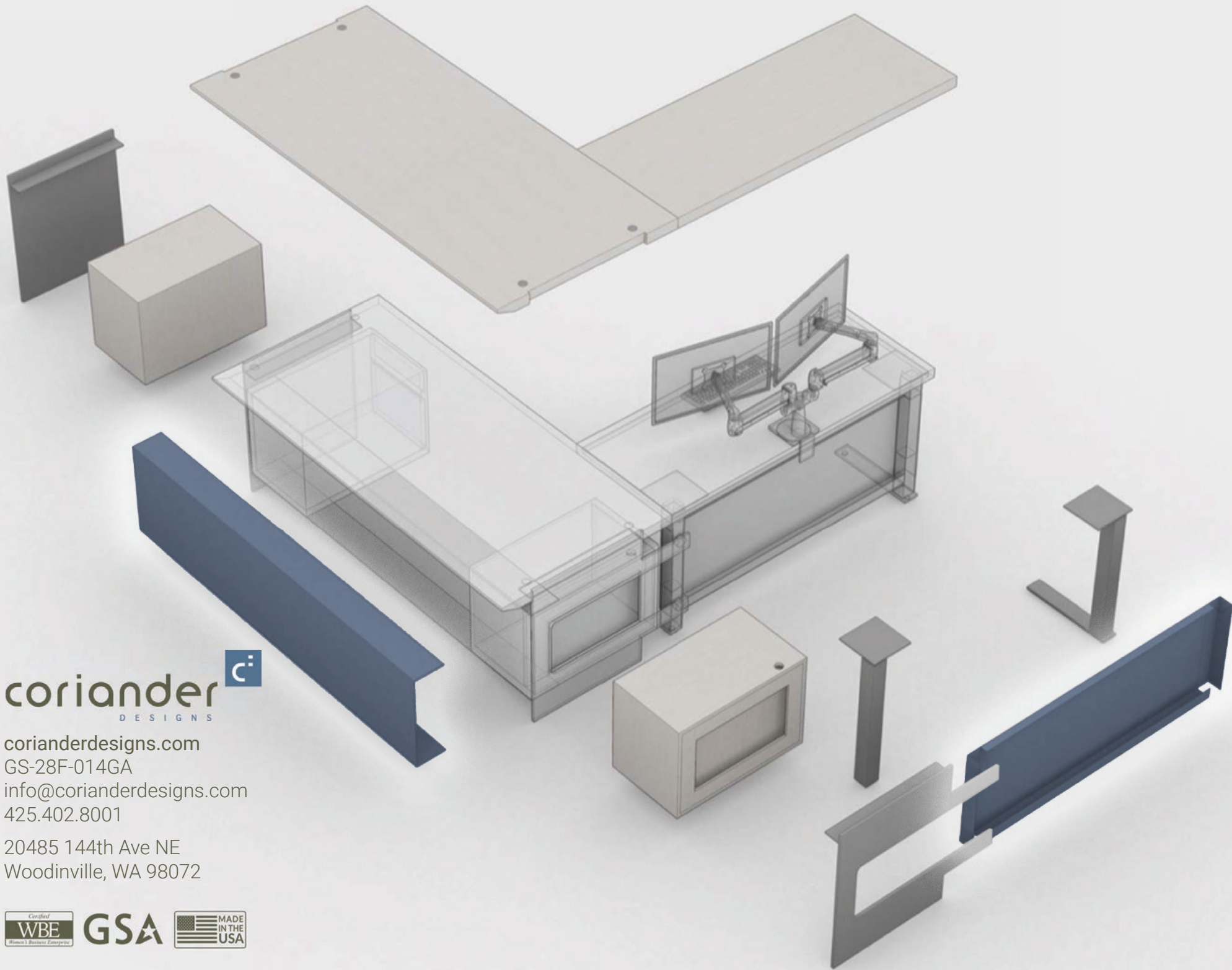

**coriander**   
DESIGNS

[corianderdesigns.com](http://corianderdesigns.com)

GS-28F-014GA

[info@corianderdesigns.com](mailto:info@corianderdesigns.com)

425.402.8001

20485 144th Ave NE

Woodinville, WA 98072

